

Starrett®

Macro Vickers Hardness Tester
Series 3842



Contents

1. Introduction
2. Main Technical Specifications
3. Installation and Regulation of the Instrument
 - 3.1 Operational conditions
 - 3.2 Unpacking and installation
 - 3.3 Introduction to the operating board and its function keys
4. Usage of the Instrument
5. Precautions of the Instrument
6. The Packing List



Macro Vickers Hardness Tester

Series 3842

1 Introduction

Our advanced Macro Vickers hardness tester 3842 is a state-of-the-art, precise testing system suitable for hardness analysis of metallic specimens in metallography laboratories or production environments.

Designed for the accurate hardness testing of small precision parts, thin materials, case hardened layers and all sorts of steel components. The Phase II 900-398 is our macro-Vickers hardness tester, covering the load range from 1kg to 50kg, with digital technology. Using guidelines for ASTM E-384/92 Vickers hardness testers standards, the 3842 digital Vickers hardness tester will offer unmatched repeatability. A perfect rugged performer suited for any environment, the Starrett Vickers hardness testers are offered with a 1 year warranty and free lifetime technical support.

The 3842 Vickers Hardness Tester is engineered to produce a clear indentation and a more precise measurement. By means of a load cell, closed circuit system for control, the CPU controls testing force to load/dwell/unload, allowing for the highest degree of accuracy. The large LCD shows the measuring methods, the testing force, the indentation length, hardness value, the dwell time of the testing force as well as the number of the measurement on its screen. All information such as diagonal lines length of indentation, hardness values, data statistics and hardness conversions can be displayed on the LCD.

2 Main Technical Specifications

Test forces 9.807N(1 kg), 19.61N(2kg), 24.52N(2.5kg) 29.42N(3kg), 49.03N(5kg),
98.07N(10kg) 196.1N(20kg), 294.2N(30kg), 490.3N(50kg)

Test Force Application Method: Automatic loading and unloading

Testing Results: Automatic

Amplification of the Microscope: *Both 10x and 20x can be used for measurement

Objective	10x	20x
Measuring eyepiece	10x	10x
Total Amplification	100x	200x
Resolution Rate	0.25µm	0.125 µm

Dwell time of the test force: 0~60s (5 second as a unit)

Max. height of the specimen: 170mm

Max Depth of specimen: 130mm

Weight: 110 lbs (50kg)

Light Source: 12V – Adjustable 15-20 watt

Power source: AC110V/50~60Hz

Auto-Power Saver Shuts off light source after 10 minutes

Overall dimension (L×W×H): (530×225×630)mm

3 Unpacking, Operational Conditions and Installation

Unpacking and Installation

Cut the belt on packing crate; remove the anti-shock cushion and remove the instrument and the accessories kit from the crate.

Place the instrument on a solid working table. (for the dimensions of the working space, see Fig 1) **(580mm)**

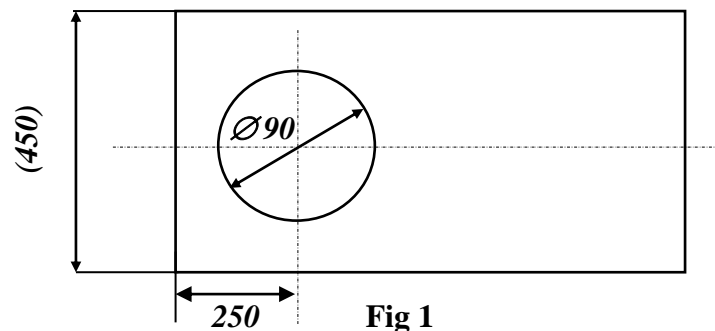

IMPORTANT!

Do Not Discard Shipping Crate as This May
be Needed for Future Transportation.

General Safety Instructions

1. Never use clamps, straps, any other tooling or equipment to mount specimen to the tester anvil.
2. Always use the proper anvil supplied.
3. Be sure to use proper indenter and weight for material and hardness to be tested.

Hardness Tester Maintenance

1. Consult operation instructions for specific maintaining and adjusting procedures.
2. Keep the tool clean for best results.
3. Remove adjusting tools and wrenches. Form habit of checking that adjusting tools are removed before using machine.
4. Keep all parts in working order. Check to determine that the parts will operate properly and perform their intended function.
5. Check for damaged parts. Check for alignment, binding, breakage, mounting and any other condition that may affect tool's operation.

6. Part that is damaged should be properly repaired or replaced. Do not perform makeshift repairs. (Use the parts list provided to order replacement parts.)

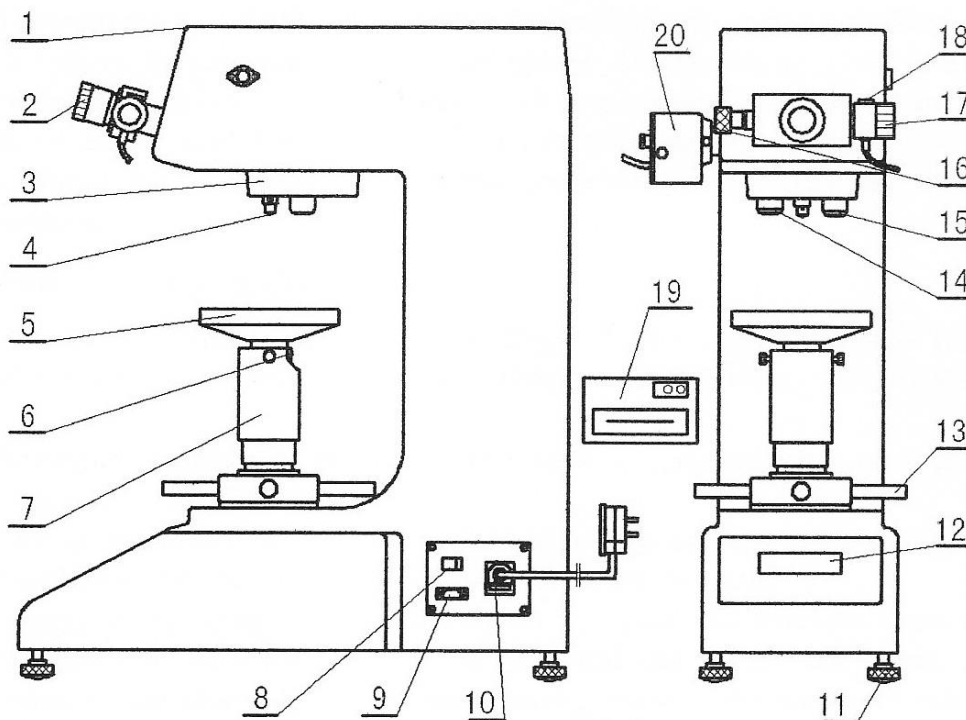
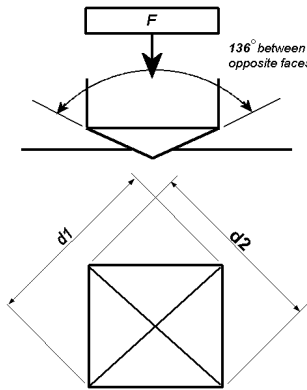

Fig.1

1. Upper Cover 2. Eyepiece 3. Turntable 4. Indenter 5. Testing Table 6. Screw
 7. Lifting Screw 8. Power Switch 9. RS232 10. Power Cord and Fuse 11. Regulating Screw
 12. Screen 13. Hand Wheel 14. 10^xObjective 15. 20^xObjective 16. Left Drum Wheel
 17. Right Drum Wheel 18. Measuring Button 19. Printer 20. Light source of the eyepiece

Vickers Hardness Test

The Vickers hardness test method consists of indenting the test material with a diamond indenter, in the form of a right pyramid with a square base and an angle of 136 degrees between opposite faces subjected to a load of 1 to 100 kgf. The full load is normally applied for 10 to 15 seconds. The two diagonals of the indentation left in the surface of the material after removal of the load are measured using a microscope and their average calculated. The area of the sloping surface of the indentation is calculated. The Vickers hardness is the quotient obtained by dividing the



kgf load by the square mm area of indentation.

F = Load in kgf

d = Arithmetic mean of the two diagonals, d_1 and d_2 in mm

HV = Vickers hardness

$$HV = \frac{2F \sin \frac{136^\circ}{2}}{d^2} \quad HV = 1.854 \frac{F}{d^2} \text{ approximately}$$

When the mean diagonal of the indentation has been determined the Vickers hardness may be calculated from the formula, but is more convenient to use conversion tables. The Vickers hardness should be reported like 800 HV/10, which means a Vickers hardness of 800, was obtained using a 10 kgf force. Several different loading settings give practically identical hardness numbers on uniform material, which is much better than the arbitrary changing of scale with the other hardness testing methods. The advantages of the Vickers hardness test are that extremely accurate readings can be taken, and just one type of indenter is used for all types of metals and surface treatments. Although thoroughly adaptable and very precise for testing the softest and hardest of materials, under varying loads, the Vickers machine is a floor standing unit that is more expensive than the Brinell or Rockwell machines.



Macro Vickers Hardness Tester

Series 3842

Operating Conditions:

The 3842 Macro Vickers Hardness Tester is a precise yet sensitive instrument that should be handled with care. Please be sure to mount on a sturdy bench in a clean temperature-controlled room for best results. This instrument should be perfectly level before performing any tests.

Set Up - Installation:

Take out the 4 Leveling Feet (11) out of the accessories kit and screw them in the holes on the base of the instrument. Unpack the gauze band wrapped on the Up and Down Lead Screw (7) and Hand Wheel (13) (Fig.2).

Rotate the hand wheel(13) to make the indenter(4) face the front of the machine and then gently remove the anti-rust/shock paper on the indenter with both hands. Clean the indenter gently with rubbing alcohol.

Remove the dust protector from the eyepiece tube and then remove the eyepiece(2) from the accessory kit and place into the eyepiece tube. Insert the 5-hole plug into the port on the right side of the machine.

Set-up cont'

Take out flat testing anvil(5) and place the shaft of the anvil inside the hole of the elevation screw(7). Snug with screws(6) and wipe grease/oil from anvil.

Remove the bubble leveling gauge from the accessory kit and place it on top of the anvil. Adjust the 4-leveling feet until the desired level is reached.

KEYPAD FUNCTIONS: (Fig.5).

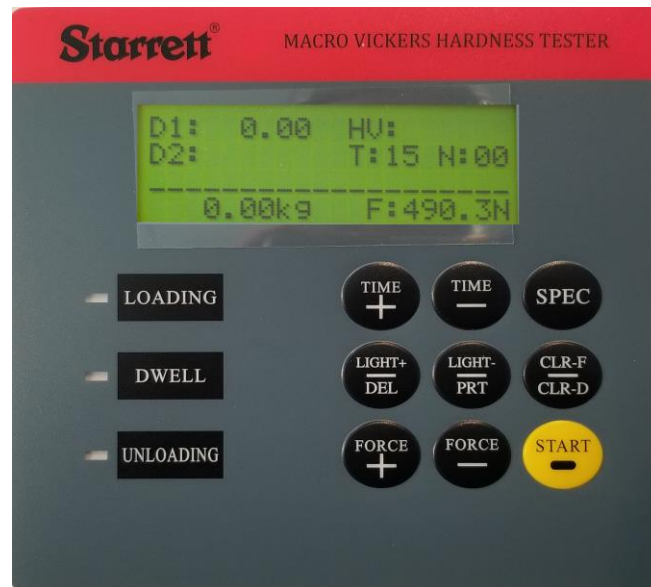

TIME/+ Time adding key. 5 second interval/press Also used for date setting.

TIME/- : Time reduction key. 5 second interval/press. Also used for date setting.

SPEC: Multi function key. 1) Must press to use “lower shift keys” on keypad.

2) Press to obtain date and time

FORCE/+: Increase Test Force

FORCE/-: Decrease Test Force

LIGHT+/DEL: 1) Increase light source

2) Delete present result on display (must press SPEC key first to make DEL function)

LIGHT-/DPRT: 1) Decrease light source

2) Print Output key (must press SPEC key first to make PRT function)

CLR-F/CLR-D: 1) CLR-F is the Zero setting key for the test force value if displayed

2) CLR-D is the Zero setting key for the graduated lines in the eyepiece.

(Set zero to D1 and D2) (must press SPEC key first to make CLR-D function)

START: 1) Test force application key, automatic loading, dwell, unloading.

2) Emergency Stop key. Press this key to immediately stop test and reverse itself back to the original start position.

3.1 Usage of the Instrument

3.1.1 Switch the power source on. The light source and the LCD screen are both lit up at the same time. At this point, the LCD screen displays as follows:

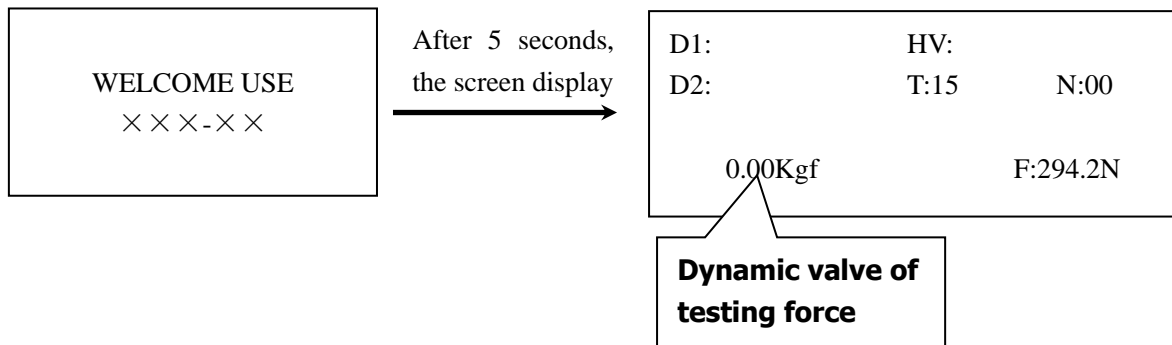

D1/D2: Diagonal length of indentation; HV: Vickers hardness value; T: Dwell time; N: Numbers of measurements; F: Testing force value;

- 3.1.2 Once the working screen appears, you can revise the dwell time, testing force value and luminosity of light source, etc according to operator's requirement.
- 3.1.3 Rotate the protecting cover of the indenter to make the 20[×] objective face the front of the instrument. (This instrument is equipped with a positioning device, you will feel it click into a position socket when you rotate the protecting cover. The general amplification is 200[×])
- 3.1.4 Place the standard block or the specimen on the testing table and then rotate the hand wheel to raise the table. When the block or the specimen comes into the distance of 3~4 mm (20[×] objective) under the objective, begin observing the view through the eyepiece. At this point, in the center of the vision field of the eyepiece appears a bright spot, which is alerting you that you are very close to the focusing plane. At this time raise the testing table up slowly until the block or specimen surface forms a clear image in the micro eyepiece, which indicates the focusing operation is completed. (The micro eyepiece, the objective and the working piece are in the focusing state.)
- 3.1.5 The luminosity of the light source in the vision field can be regulated through the keys "LIGHT+" or "LIGHT-" on the operational board.
- 3.1.6 If there is a need to have a large vision field on the block or on the specimen, just shift the 10[×] objective in the frontal direction of the instrument. At this time, the general amplification is 100[×]. Both the 10[×] objective and the 20[×] objective can be used for the measurement.

NOTE: 1. When toggling between the objectives 10[×] and 20[×], there might be a slight change in the vision field. Just adjust slightly the up-and-down lead-screw until the focusing plane is clear.

2. When testing indentation size covers over 60% of the vision field, the hardness value for this measurement is erroneous

You can have 2 choices:

- a) Reduce the testing force;
- b) When it is stipulated that the testing force can't be changed in the technical file, you must choose the objective with small rate amplification. This is the function that both objectives can measure.

3.1.7 After the focusing operation is finished, turn the indenter to the front of the instrument. At this point, the distance between the tip of the indenter and the plane of the specimen is about 0.4~0.5 mm. When an irregular-shaped specimen is to be tested, take care not to damage the indenter. The indenter must be perpendicular to the surface at all times.

3.1.8 According to the requirements of the test, set the dwell time of the test force with the keys on the operating board. Each push of the button accounts for 5 seconds, with the key "TIME+" adding time and the key "TIME-" reducing time.

3.1.9 Press the key "START" on the operating board and apply the test force; at this point (LOADING) LED is lit.

3.1.10 After the test force is applied, DWELL LED lights up. At this time the LCD screen shows the dwell countdown of the time selected. When the dwell time is up, the test force UNLOADING LED lights up. After test force UNLOAD LED lights out, **shift the objective selected to front of instrument.**

NOTE: When the UNLOAD LED is still on, do not turn the protecting cover of the indenter; otherwise it would cause damage to the instrument. After pressing the "START" Key, if you find the objective is in front of instrument instead of the penetrator, Please be patient to wait until the machine performs the test cycle. **DO NOT ROTATE DURING TEST. Serious damage can occur**

3.4.11 Rotate the turntable counter-clockwise to place the 20[×] objective in front of the main body. Turn the drum wheel on both left and right side of micro eyepiece, so that the operator could see the two graduated lines move closely as shown in Fig 6. Continue turning eyepiece until the inner sides of graduated lines reach critical state with no space between them to allow the light to penetrate as shown in Fig 7. Now press the SPEC key and then press "CLR-D" key to clear the zero, at this point, it has finished to set zero for the eyepiece, the values of D1 and D2 will show 0.00 on the LCD screen.

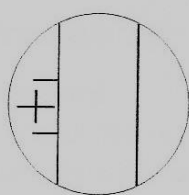

Fig.6

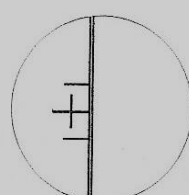

Fig.7

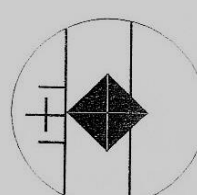

Fig.8

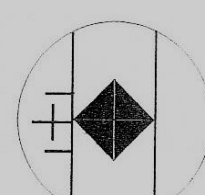

Fig.9

NOTE: The 3842 has memory for setting the zero. The only time you need to reset the zero is when the instrument is restarted.

Measurement of Diagonal length of indentation:

- 3.4.12 Observe the indentation in the eyepiece; rotate the handwheel to focus until the image quality becomes clear.
- 3.4.13 Rotate the left drum wheel to make the inner side of the LEFT graduated line tangent to the diagonal line of the indentation, See Fig 8.
- 3.4.14 Rotate the right drum wheel to make the inner side of the RIGHT graduated line tangent to the right tip of the indentation as shown in Fig9.
- 3.4.15 Press the measure button on the micro eyepiece. Now the D1 on the screen displays the length of the diagonal line.
- 3.4.13 Rotate the micro eyepiece clockwise by 90°. The inner line should remain on the tip of the indentation without any space between them and begin to measure the other diagonal line in the same way as shown above. When it is determined, press the button on the micro eyepiece. And the D2 on the screen indicates the length of this diagonal line. The 3842 will automatically compute the hardness value (HV). The hardness value indicated is calculated by instrument according to the arithmetic mean of the length of two diagonal lines.
If the operator is not sure of the correctness of the measurement, press SPEC key and then press DEL key to repeat a new measurement.
At the end of your measurement, lower the elevating table and prepare to take a new test.
- 3.4.14 When the indentation observed in the micro eyepiece is too large or too small to measure precisely, it is necessary to re-select the test force to suit the requirement of the test. The other way is to use the 10^x objective to measure a large indentation. If the numbers of test N>1, the results can be printed on the built-in micro printer. Press SPEC key first and then press PRT key. If you need to send output via RS232, you must set RS232 Hyper Terminal as described in the section below.

3.5 The regulation of the hardness tester and the precautions for the operation.

3.5.1 The square pyramidal diamond indenter

- a.) The diamond indenter and the indenter shaft are important parts of the instrument, and hence it is necessary to take care not to touch the indenter during the operation.
- b.) In order to assure the precision of the measurement, it is important to keep the indenter clean. If it is covered with grease or dust, it should be cleaned carefully.
- c.) The round column of the indenter is marked with a red dot. Make sure the RED dot on the indenter is facing the frontal direction when it is installed and the focus of the diagonal line of the indentation should be aligned with the red dot. It is possible to make the alignment of the cross-shaped in the micro eyepiece line with the diagonal line of the indentation. If the indentation observed is not aligned with the cross-shaped line, please unscrew the screw on the indenter, turn the indenter a bit and then fasten the screw, and then make the alignment again through tests until the alignment is all right to your satisfaction (See Fig 3)

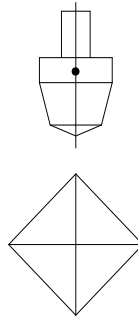

Fig 3

3.5.2 The micro eyepiece

- a) Every observer should adjust the lens in front of the micro eyepiece according to his personal visual line so as to make the graduated line observed in the vision field clear. Turn up-and-down rotating wheel slowly until the block or specimen surface forms clear image in micro eyepiece. Then set zero to micro eyepiece as Item 3.4.11. (Every testing operator should set zero according to of his personal visual line.)
- b) As the micro eyepiece is put in the micro eyepiece tube, it is necessary to turn the micro eyepiece by 90° during the measurement of the two diagonal lines of the indentation. During the turning operation, the micro eyepiece should move along the inner side of the tube without any space between them; otherwise it would affect the correctness of the measurement.

3.5.3 The light source of the micro eyepiece

- a.) The instrument adopts the cold light source for the lighting. The centrality of the center position of the light source would exert a direct influence on the quality of the image of the indentation. During assemblage of the instrument, the position of the center of the light source is already adjusted, and hence the client does not need to adjust it.
- b.) **The light intensity of the light source is regulated by the key “LIGHT+” or “LIGHT-” on the operational board. The operator should adjust the light so as to have a soft vision field for the observation.**

3.5.4 The specimen

- a) The surface of the specimen must be clean, as the grease or the dirt on the surface would make the edge of the image of the indentation vague, thus affecting the precision of the measurement. Please clear the specimen with alcohol-based solution.
- b) When thin filaments, thin pieces and small bits are used as the specimens, the special accessories such as fine wire test table, thin specimen test table, fork-shape test table and metallurgical equipment can be used. The fine wire test table, thin specimen test table and fork-shape test table holder should be used to hold the specimens respectively on the large testing table for the measurement. If the specimen is too small to be held by the test table, the specimen should be inlaid and polished for the measurement.
- c) The minimum thickness of the specimen should be more than 10 times the depth of indentation. Check the backside of the sample for any deformation caused by the penetration of the diamond. If deformation is visible, the test is erroneous.

Thickness—the thickness of the specimen tested shall be such that no bulge or other marking showing the effect of the test force appears on the side of the piece opposite the indentation. The thickness of the material under test should be at least ten times the depth of the indentation. This is also to be used as a



Macro Vickers Hardness Tester

Series 3842

Hardness Symbol	Max Allowed Tolerance of Display Value $\pm\%$															
	Hardness HV															
	50	100	150	200	250	300	350	400	450	500	600	700	800	900	1 000	1 500
HV 0.01																
HV 0.015	10															
HV 0.02	8															
HV 0.025	8	10														
HV 0.05	6	8	9	10												
HV 0.1	5	6	7	8	8	9	10	10	11							
HV 0.2		4		6		8		9		10	11	11	12	12		
HV 0.3		4		5		6		7		8	9	10	10	11	11	
HV 0.5		3		5		5		6		6	7	7	8	8	9	11
HV 1		3		4		4		4		5	5	5	6	6	6	8
HV 2		3		3		3		4		4	4	4	4	5	5	6
HV 3		3		3		3		3		3	4	4	4	4	4	5
HV 5		3		3		3		3		3	3	3	3	3	4	4
HV 10		3		3		3		3		3	3	3	3	3	3	3
HV 20		3		3		3		3		3	3	3	3	3	3	3
HV 30		3		3		2		2		2	2	2	2	2	2	2
HV 50		3		3		2		2		2	2	2	2	2	2	2
HV 100				3		2		2		2	2	2	2	2	2	2

1 When the indentation diagonal length is less than 0.020 mm, the table will not display the value.

2 For intermediate values, the maximum allowable error can be obtained by interpolation.

3 When the Micro Hardness Tester value in the table is 0.001mm or indentation diagonal length of the average of 2% of the maximum permissible error given, please select the higher value.

7. ACCESSORIES:

Packing List:

The main instrument (including a macro Vickers Indenter, a 20^X Objective and a 10^X Objective)

Item	Descriptions	Quantity
1	Large Round Anvil	1PC
2	Small V-Anvil	1 PC
3	10x Digital Micro Eyepiece	1 PC
4	Thin Specimen Testing Table	1 PC
5	Screw Drivers	2 PCS
6	Leveling Feet	4 PCS
7	Bullseye Level	1 PC
8	Power Cord	1 PC
9	Prepare Fuses (1A)	2 PCS
10	Vickers Hardness Blocks	2(one mid range HV0.2 block and one high HV1
11	Operation Manual	1 PC



TECHNICAL SUPPORT: (201) 962-8352